

**Step 1**  
**Separate sensor housings.**

Use a small screwdriver to push in and down on the latch at the top of the sensor, and separate the housings.

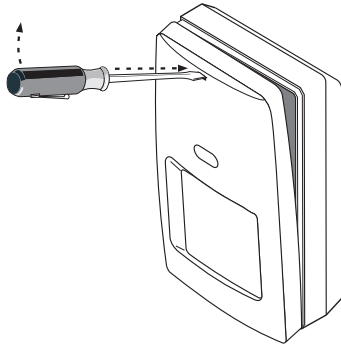

**Step 2**  
**Remove the Printed Circuit Board.**

Press outward on the latch on the right side of the housing. Then gently pull the printed circuit board (PCB) outward to the left.

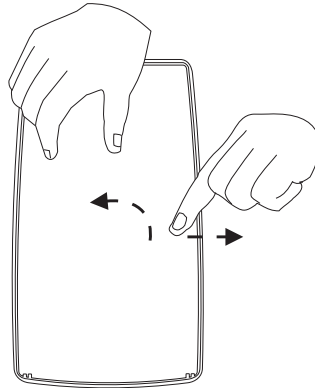

**Step 3**  
**Mount the sensor.**

Carefully break out the mounting/wiring knockouts on the rear housing, and mount the housing in the desired location.

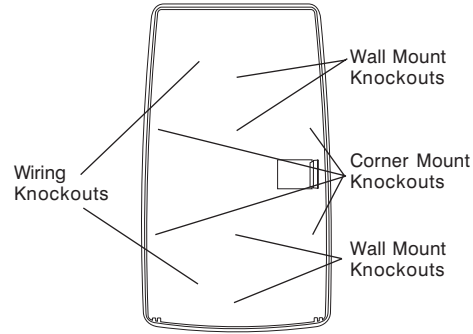

**Maximum range is obtained at a mounting height of 2.3 m (7'6").** Make sure the sensor has a clear line-of-sight to all areas you wish to protect. If the PIR or microwave is blocked, the unit will not alarm.

Aim the sensor toward the interior of the room, pointing away from windows, moving machinery, fluorescent lights, and heating/cooling sources.

**Step 4**  
**Wire the sensor.**

Observing the proper polarity, wire the unit as shown (use 14 to 22 AWG).

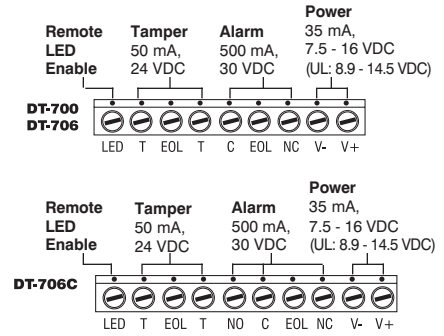

Reverse polarity will not damage the sensor.

**NOTE:** For proper wiring methods, refer to the National Electrical Code, NFPA 70.

**Step 5**  
**Reassemble the sensor.**

After wiring the sensor, return the PCB to the rear housing and snap the front housing back in place.

**Step 6**  
**Walk-test the sensor.**

Apply power and let the sensor warm up for three minutes.

Use the dip switches to test the PIR and microwave technologies separately and together.

**NOTE:** After 10 minutes of switch inactivity, the sensor will revert to normal (alarm) mode, regardless of switch positions. When any switch is toggled, the 10 minute timer resets.

To walk-test the microwave:

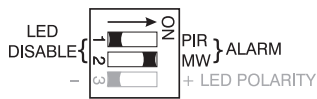

Walk across the protected area at the ranges to be covered. Two to four normal steps should make the LED light. When there is no motion in the protected area, the LED should be off.

Walk-test the microwave and PIR together. This is the normal (alarm) mode. Both must trip for the sensor to alarm.

To walk-test both technologies together:



**Step 7**  
**Adjust the microwave range.**

Turn the microwave range thumbwheel (R1) **counterclockwise** to decrease the microwave range to **minimum**. (Range is factory set at maximum.)

As you perform the walk-test, gradually turn the thumbwheel clockwise until the desired range is obtained.

**NOTE:** It is important to adjust the microwave range to fit the size of the room.

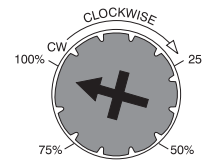

To walk-test the PIR:



To disable the LED:

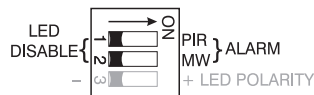

**Step 8**  
**Set sensor polarity.**

Switch S1, position 3 allows you to set the sensor polarity to disable the LED when the system is armed. If the control panel's output goes to negative voltage (0 to +2V) when armed, the switch should be in the - position (OFF); if the panel's output goes to positive voltage when armed (+3 V to +24 V), the switch should be in the + position (ON).

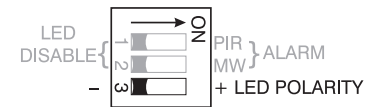

SW1-3 Polarity LED Disable	
+ LED	Positive Voltage (+3 V to +24 V)
- LED	Negative Voltage (0 to +2 V)

**NOTE:** If the LED Enable terminal is not connected or open circuit, the LED is Enabled, unless the LED Disable switches are OFF.

PIR range is determined by the mounting height and angle, or by masking specific PIR zones.

## MICROWAVE SUPERVISION

If the microwave technology stops sending or receiving signals, the sensor will lock into an alarm condition. The LED at the sensor, however, will not light.

If the microwave regains its signal, the sensor (and LED) will return to normal operation.

**NOTE:** The DT-700 Series sensor should be tested **at least once each year** to ensure proper operation.

## DETECTION PATTERNS

DT-700 TOP VIEW  
Wall Mounted  
Wide Angle Lens with  
Typical Microwave  
Pattern

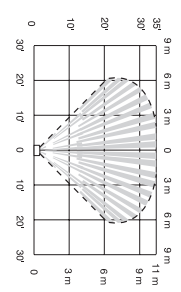

DT-700 SIDE VIEW  
Wide Angle Lens

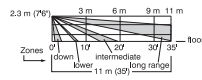

DT-706 TOP VIEW  
Wall Mounted  
Wide Angle Lens with  
Typical Microwave  
Pattern

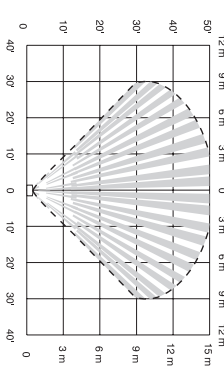

DT-706 SIDE VIEW  
Wide Angle Lens

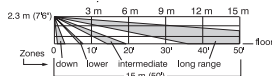

## OPTIONAL LENSES DETECTION PATTERNS

DT-700 TOP VIEW  
Curtain Lens

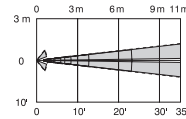

DT-700 SIDE VIEW  
Curtain Lens

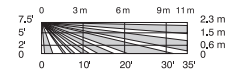

DT-706 TOP VIEW  
Curtain Lens

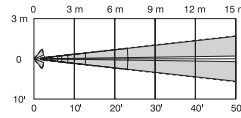

DT-706 SIDE VIEW  
Curtain Lens

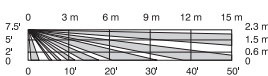

DT-700 TOP VIEW  
Pet-Alley Lens

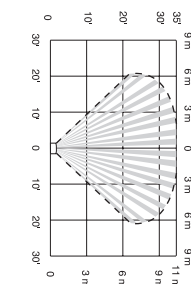

DT-700 SIDE VIEW  
Pet-Alley Lens

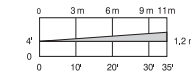

DT-706 TOP VIEW  
Pet-Alley Lens

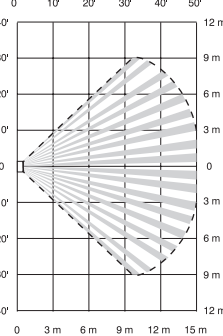

DT-706 SIDE VIEW  
Pet-Alley Lens

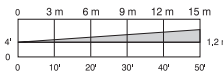

## PRODUCT SPECIFICATIONS

### Range:

DT-700	11 m x 12 m (35' x 40')
DT-706	15 m x 18 m (50' x 60')
DT-706C	15 m x 18 m (50' x 60')

### Alarm relay:

DT-700, DT-706  
Energized Form A (NC)  
500 mA, 30 VDC

DT-706C  
Energized Form C  
500 mA, 30 VDC

### Tamper switch:

(NC) 50 mA, 24 VDC

### Power requirements:

7.5 - 16 VDC (UL: 8.9 - 14.5 VDC)  
35 mA, 12 VDC  
AC Ripple: 3V peak-to-peak at nominal 12VDC

### Frequencies:

24.125 - 24.20 GHz  
Center band varies depending on country

### PIR white light immunity:

8,000 Lux

### RF immunity:

30 V/m, 10 MHz - 1000 MHz

### Operating temperature:

-25° to +65° C (-13° to +149° F)  
5 - 95% relative humidity (non-condensing)

### PIR fields of view:

Standard lens  
22 long range edges  
12 intermediate edges  
6 lower edges  
4 down edges

### Dimensions:

11.9 cm H x 7.1 cm W x 4.2 cm D  
(4.685" H x 2.795" W x 1.654" D)

### Sensitivity:

2 - 4 steps within field of view

### Accessories:

Flush Mount Kit  
Lens Option Kit 17  
Swivel Mount Bracket (Model SMB-10)

### Approvals/listings:

CE (EMC Directive: Commercial, Residential,  
and Light Industrial)  
FCC  
IC  
UL listed

**IMPORTANT:** In UL certificated installations, the DT-700 Series Sensor must be connected to a UL listed power supply or UL listed control unit capable of providing a **minimum of four hours** of standby power.

**FCC Notice:** This equipment has been tested and found to comply with the limits for a field disturbance sensor, pursuant to Part 15 of the FCC Rules. The user is cautioned that changes or modifications not expressly approved by C&K Systems could void the user's authority to operate this equipment.

This equipment has been tested and found to comply with the limits for a Class B digital device, pursuant to Part 15 of the FCC Rules. These limits are designed to provide reasonable protection against harmful interference in a residential installation. This equipment generates, uses and can radiate radio frequency energy and, if not installed and used in accordance with the instructions, may cause harmful interference to radio communications. However, there is no guarantee that interference will not occur in a particular installation. If this equipment does cause harmful interference to radio or television reception, which can be determined by turning the equipment off and on, the user is encouraged to try to correct the interference by one or more of the following measures:

- Reorient or relocate the receiving antenna.
- Increase the separation between the equipment and receiver.
- Connect the equipment into an outlet on a circuit different from that to which the receiver is connected.
- Consult the dealer or an experienced radio/TV technician for help.

**IC Notice:** Operation is subject to the following two conditions: (1) this device may not cause interference, and (2) this device must accept any interference, including interference that may cause undesired operation of the device.

C&K is a registered trademark of C&K Components, Inc.  
DUAL TEC is a registered trademark of C&K Systems, Inc.  
Copyright 1996 C&K Systems, Inc. All Rights Reserved

<http://www.cksys.com>

5-051-458-00 Rev B

